



SZ1017a/SZ1041/SZ1051/ SZ1053

Modulating Thermostats



Description

The SZ1017a, SZ1041, SZ1051, and SZ1053 are micro-processor-based programmable thermostats designed to control air handling units with modulating economizers and/or modulating heating or cooling. The SZ1041, SZ1051, and SZ1053 have a 365-day time clock, while the SZ1017a has a 7-day time clock.

Features

- Stand-alone or network operation
- Outdoor air sensor input with heating & cooling lockout
- Adjustable delay on power-up and start-up for soft starts
- P+I control option on digital stages
- Smart Recovery
- No battery backup required
- Built-in HVAC equipment protection
- 32 character LCD display
- Six status LEDs for monitoring
- Remote room sensing capability
- User setpoint adjustment limits
- Local and remote override capability
- System and fan switching with access lockouts
- Equipment monitoring inputs and indication
- External time clock input
- Access to programming or schedule may be locked out or limited with the use of an access code
- Fahrenheit or Celsius temperature display

Contents

Description	1
Features	1
Mounting	1
Wiring	2
Setup	4
Programming	5
Setting Clock & Schedule	11
Operation	12
Checkout & Troubleshooting	16
LED Description	18
Limiting Occupant Access	18
User's Guide	19

Mounting

The SZ1017a, SZ1041, SZ1051, and SZ1053 are designed for wall mounting using two #6 sheet metal screws, either over a horizontally installed 2" x 4" junction box, or directly to block or drywall.

For best results, the thermostat should be mounted on an interior wall which reflects normal room environment, at a height of approximately five feet from the floor. Avoid areas exposed to direct sunlight, unusual heat or cool sources, open doors and windows, unventilated locations and hot or cold air from diffusers.

If using a remote room sensor, it should be mounted in the manner described above. The thermostat may then be mounted in an area which is accessible for adjusting its settings.



Caution: Remove power from thermostat prior to mounting.

Wiring

The SZ1017a, SZ1041, SZ1051, and SZ1053 use standard terminal designations for wiring. See diagram below.

REMOTE TEMPERATURE SENSOR WIRING

Use 18 AWG shielded twisted-pair grounded at the sensor mounting location. Sensor wiring runs of up to 250 feet are attainable if properly shielded wire is used and the installation environment is free of electrical noise. Sensor wire should be kept at least five feet away from line voltage wiring.

The SZ1017a, SZ1041, SZ1051, and SZ1053 accept three 2-wire remote temperature sensors. Consult the TS Series Temperature Sensor Submittal Data sheet for a complete listing of packaging and application styles. When using TCS/Basys Controls three-wire sensors, use the black and red leads and either clip or twist off the white lead. Make sure that the dip switches are set for the sensors you are using.

POWERING THE SZ1017a, SZ1041, SZ1051, and SZ1053

Superstats are powered from 24 VAC +/- 20%.

If wiring for communications, dedicated power must be used to power the Superstat. Several "S" Series thermostats may be powered from the same transformer, provided that the transformer has sufficient power. (Superstats require 8 VA @ 24 VAC.)



Caution: Do not connect to 120 VAC. When multiple TCS Basys Controls devices are using a single transformer, the polarity of the power wiring must be maintained because all TCS devices are half-wave rectified and have common return paths.

When the Superstat is used as a stand-alone thermostat without communications, the unit transformer may be used to power it. To do this, install a jumper between the "R" and "+24" terminals. The "24-" terminal must then be connected to the common side of the unit transformer.

Input Wiring for the SZ1017a, SZ1041, SZ1051, and SZ1053

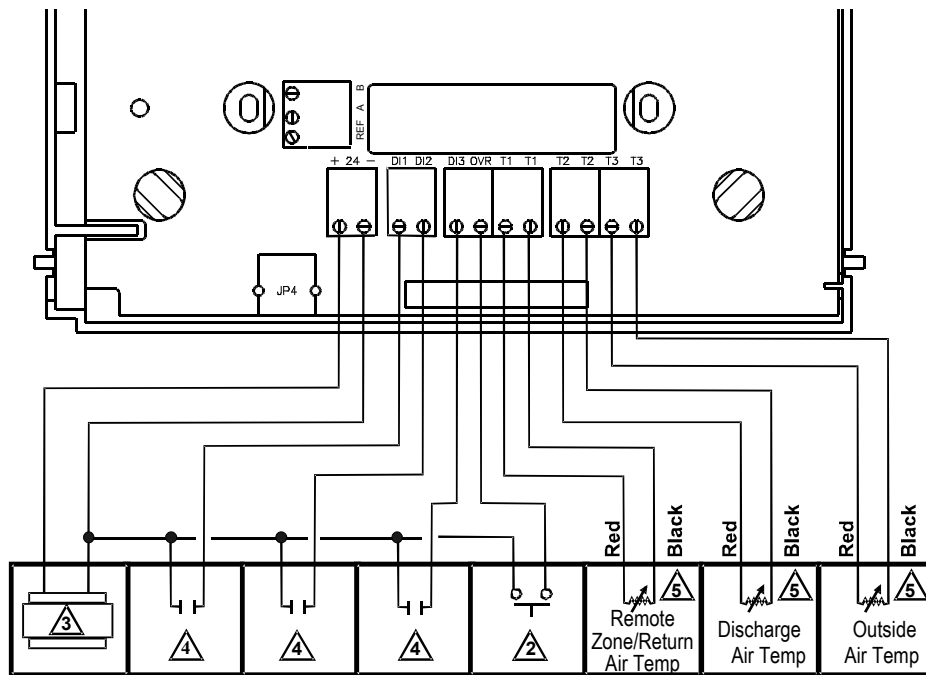

- | | |
|--|---|
| <p>1 For communication wiring, use twisted, shielded 18 AWG. Must be run separately.</p> <p>2 Dry momentary contact. Must not be powered.</p> <p>3 24 VAC transformer. See powering instructions.</p> <p>4 Dry contact. Must not be powered.</p> | <p>5 Sensor input wiring 18 AWG, twisted, shielded pair.</p> <p>6 4 to 20 mA output 600 ohm max. Do not power actuator with power from the thermostat. The thermostats are half-wave rectified, whereby the power ground is common with the signal ground.</p> <p>7 Up to nominal 28 VAC from equipment transformer.</p> |
|--|---|

Output Wiring for the SZ1017a*

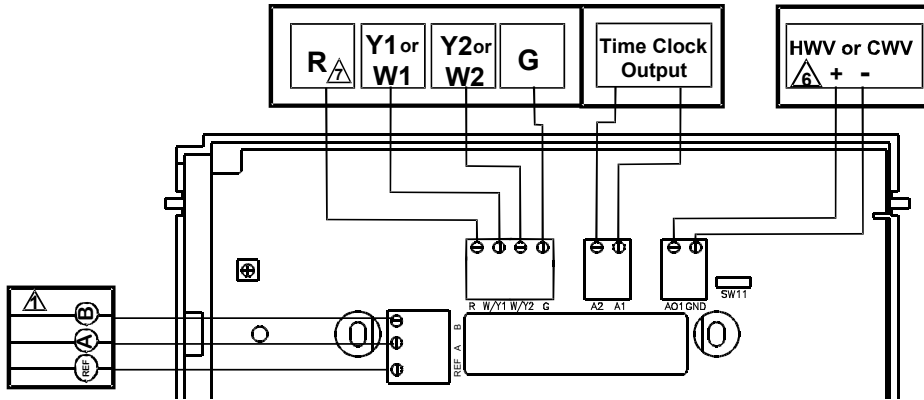

*When Relay outputs are designated as heat and cool, on the SZ1017a, SZ1051, and SZ1053.

**Add 500Ω resistor (included in bag) to convert 0/4 to 20mA to, 0/2 to 10 VDC.

Y1 or W1 = Heat
Y2 or W2 = Cool

Output Wiring for the SZ1041

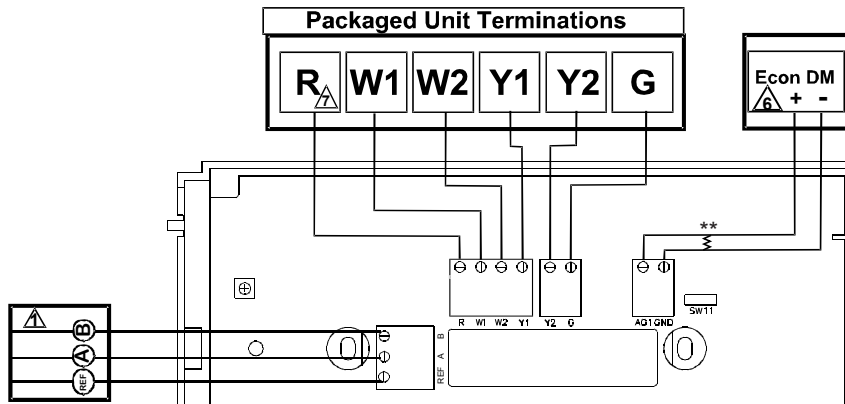

Output Wiring for the SZ1051*

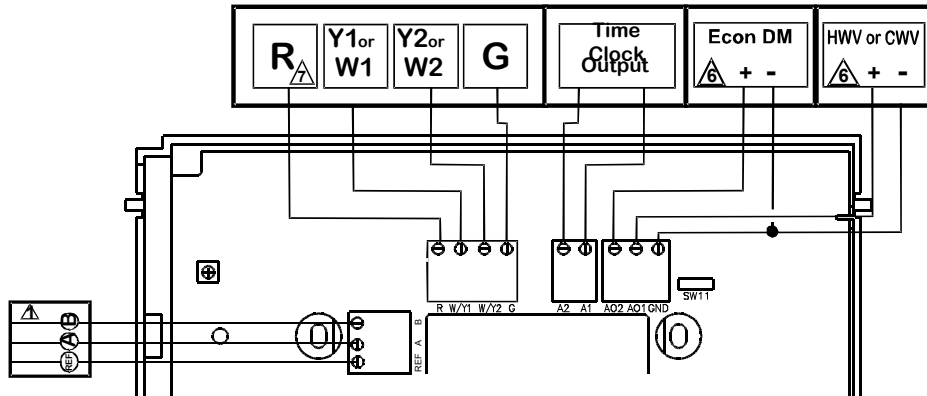

Output Wiring for the SZ1053*

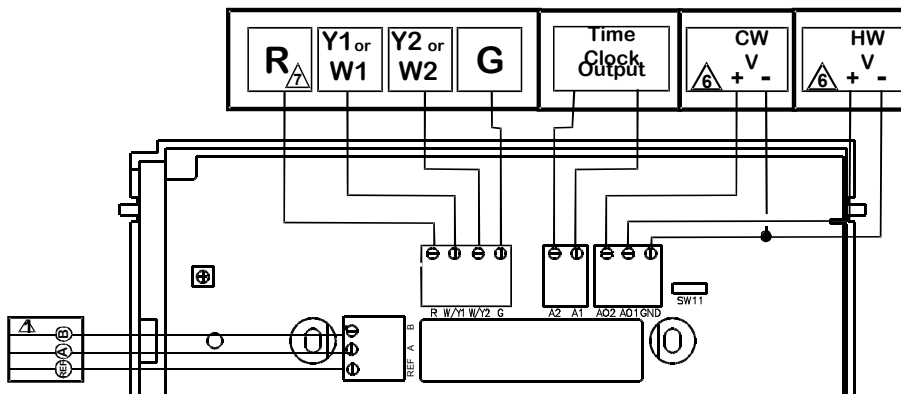

Setup

Note: If using remote sensor(s), the calibration may need to be adjusted. See “Checkout and Troubleshooting” section.

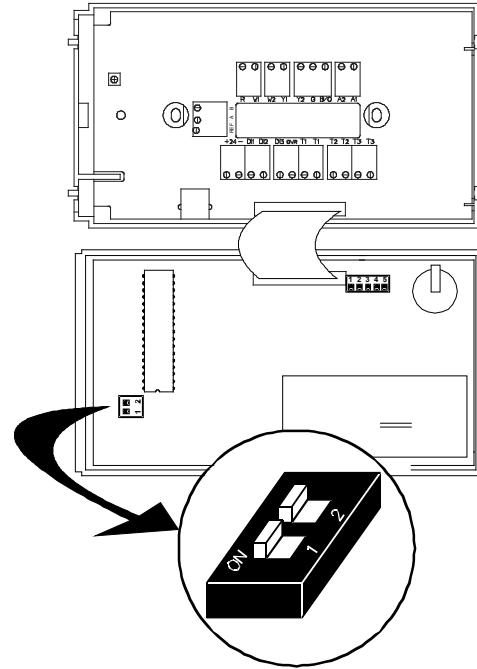
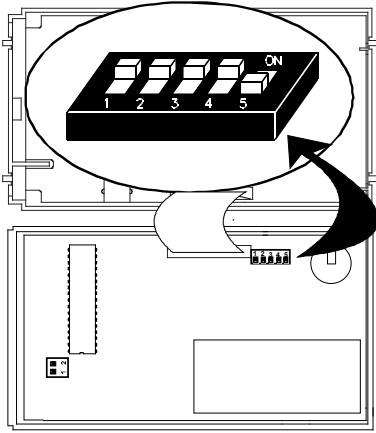

TEMPERATURE SENSOR SELECTION

The dipswitches in the cover (shown above) must be set when using remote room, discharge, and/or outdoor sensors.

Use the following guide to determine the dipswitch settings for your application.

Using built-in room sensor only. (This is the default setting.)

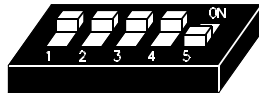

Using built-in room sensor with discharge air sensor only.



Using built-in room sensor with outdoor air sensor only.



Using built-in room sensor with both discharge and outdoor air sensors.



Using remote room sensor only.



Using remote room sensor with discharge air sensor only.

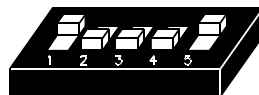

Using remote room sensor with outdoor air sensor only.



Using remote room sensor with both discharge and outdoor air sensors.



KEYPAD ACCESS

The dipswitches in the cover (shown above connected with ribbon cable) must be set in order to lock the user out of programming and/or to set the clock and schedule. Use the guide below to set these dipswitches for your application. User access may also be limited with an access code set in programming. (The fan and system switches are enabled or disabled in programming only, and require no dipswitch placement.)

Keypad access to both programming and clock setup. (This is the default setting.)

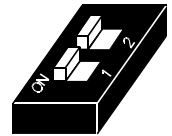

No keypad access to programming or clock setup.

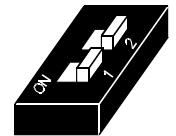

Keypad access to programming only.

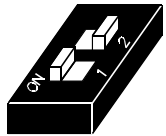

Keypad access to clock setup only.

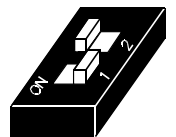

Once the dipswitches have been set and you have confirmed that the sensors are reading correctly (and program and clock setup are finished, if locking out access with dipswitches), secure the cover to the base with the two set screws located at the top right and the left side to prevent tampering.

Programming

The SZ1017a, SZ1041, SZ1051, and SZ1053 may be programmed through the keypad on the face, or with a PC.

If programming with a PC, the following must be set through the face prior to programming:

- Address (step #2)
- Baud rate (step #3)
- Temperature scale (step #4)

For more information on programming through the PC, consult your TCS software manual.

PROGRAMMING THROUGH THE KEYPAD

To access the programming screens, press the program setup button. To make changes, use the warmer and cooler keys. Access may be locked out with dipswitches, or an access code may be required.

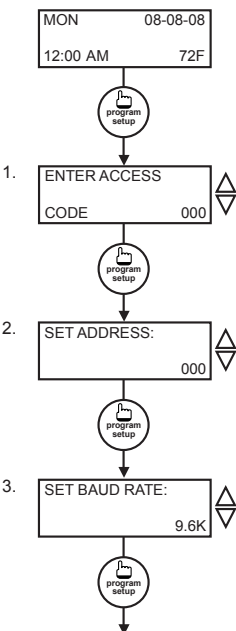
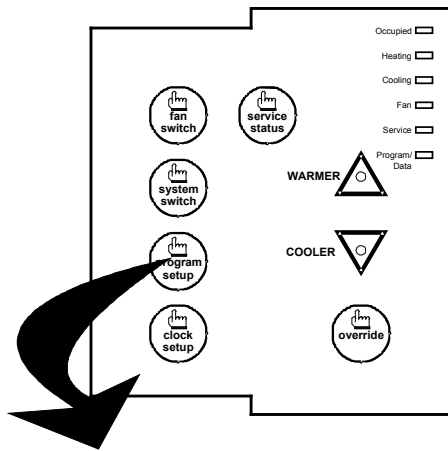

Main Monitoring Screen. Press the program setup button to access the following screens. (Date not shown on SZ1017a)

Access Code Entry Screen. Will appear if access code is required for programming. Use 248 as the default. If the wrong code is entered, it will revert to the previous screen.

Controller Address Screen. If using a PC to access the thermostat, set a unique address from 0 to 255, excluding 248.

Communication Baud Rate Screen. If using a PC to access the thermostat, all controllers on a network must be set to the same baud rate. Choose between 2.4K, 4.8K, 9.6K and 19.2K.

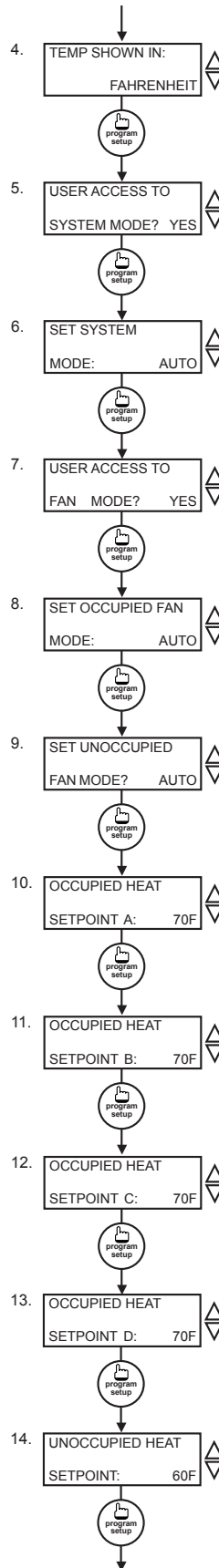

Display Type Screen. Choose between FAHRENHEIT and CELSIUS for temperature indication.

System Access Screen. Choose whether or not to enable user's access to the system switch to set the system mode.

System Mode Screen. Choose from AUTO, HEAT, COOL, or OFF for system mode. In the OFF mode, all outputs are off.

Fan Access Screen. Choose whether or not to enable the user's access to the fan switch to set the occupied fan mode.

Occupied Fan Mode Screen. Choose between ON (continuous), COOL (gas heat or no heat), or AUTO for your fan run times during the occupied modes.

Unoccupied Fan Mode Screen. Choose from AUTO or COOL for your fan run times in the unoccupied mode.

Occupied Heat Setpoint Screen. Set the heat setpoint for this occupied period.

Occupied Heat Setpoint Screen. Set the heat setpoint for this occupied period.

Occupied Heat Setpoint Screen. Set the heat setpoint for this occupied period.

Occupied Heat Setpoint Screen. Set the heat setpoint for this occupied period.

Unoccupied Heat Setpoint Screen. Set the unoccupied heat setpoint.

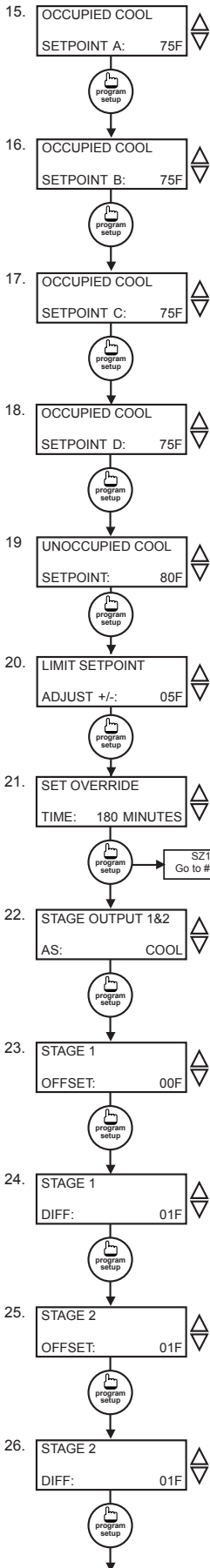

Occupied Cool Setpoint Screen. Set the cool setpoint for this occupied period.

Occupied Cool Setpoint Screen. Set the cool setpoint for this occupied period.

Occupied Cool Setpoint Screen. Set the cool setpoint for this occupied period.

Occupied Cool Setpoint Screen. Set the cool setpoint for this occupied period.

Unoccupied Cool Setpoint Screen. Set the unoccupied cool setpoint.

User Setpoint Limit Screen. Enter the number of degrees you want the user to be allowed to change the preset occupied setpoints up or down.

Override Time Screen. Enter the number of minutes (0 to 255) that the thermostat will maintain occupied setpoints when overridden.

Stage Mode Screen. Choose whether stage 1 and 2 perform heating or cooling functions, Heat & Cool or whether both stages are to be disabled.

Stage 1 Offset Screen. Enter an offset value for stage 1. First stage is normally 0 offset. This screen is not displayed if stage outputs 1 and 2 are disabled.

Stage 1 Differential Screen. Enter a differential value for stage 1. This screen is not displayed if stage outputs 1 and 2 are disabled.

Stage 2 Offset Screen. Enter an offset value for stage 2. This screen is not displayed if stage outputs 1 and 2 are disabled.

Stage 2 Differential Screen. Enter a differential value for stage 2. This screen is not displayed if stage outputs 1 and 2 are disabled.

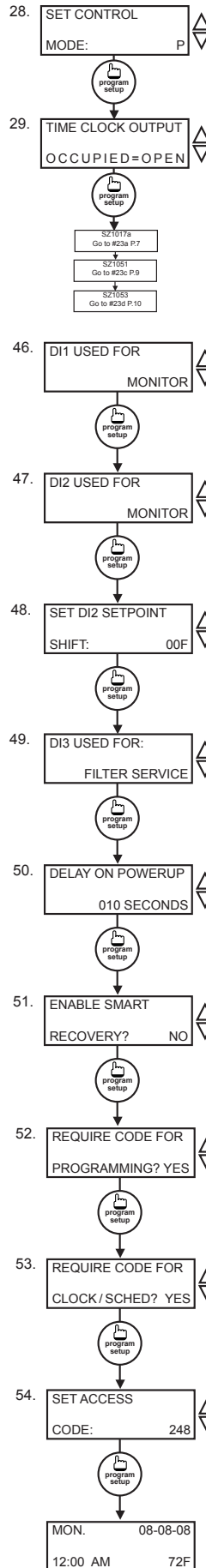

Control Mode Screen. Enter whether you want to control by temperature only (P) or add a time factor (P+I). This is applied to both stage outputs.

Time Clock Output Screen. Choose whether the auxiliary output will be OPEN during occupied periods (and closed during unoccupied periods) or CLOSED during occupied periods (and open during unoccupied periods).

DI1 Choice Screen. Choose DI1 as FAN PROVING or a MONITOR point. Select MONITOR if unused.

DI2 Choice Screen. Choose DI2 as SERVICE, AQUASTAT, ECON or MONITOR. Select MONITOR if unused. (Some options shown are ONLY available on specific models.)

DI2 Shift Screen. Enter the setpoint shift value. This screen will only appear if DI2 is set to MONITOR.

DI3 Choice Screen. Choose FILTER SERVICE, EXTERNAL OVERRIDE, or EXTERNAL TIME CLOCK. Select EXTERNAL OVERRIDE if unused.

Delay On Powerup Screen. Enter a value in seconds, such that when the unit is powered up, control is delayed for this amount of time.

Smart Recovery Screen. Choose whether or not smart recovery will be used. *Note: Smart Recovery is not available when DI3 is used as EXTERNAL TIME CLOCK.*

Programming Access Screen. Choose whether or not a code will be required to enter programming setup. A dipswitch option to lock out access altogether is also available.

Clock and Schedule Access Screen. Choose whether or not a code will be required to enter clock and schedule setup. A dipswitch option to lock out access altogether is also available.

Access Code Screen. Enter an access (0 to 255) code that will be used to enter the programming and/or clock and schedule setups if access code has been required in the last two steps. The default is 248.

Main Monitoring Screen. (Date not shown on SZ1017a.)

(Instructions continued on page 11.)

SZ1017a Programming Sequences

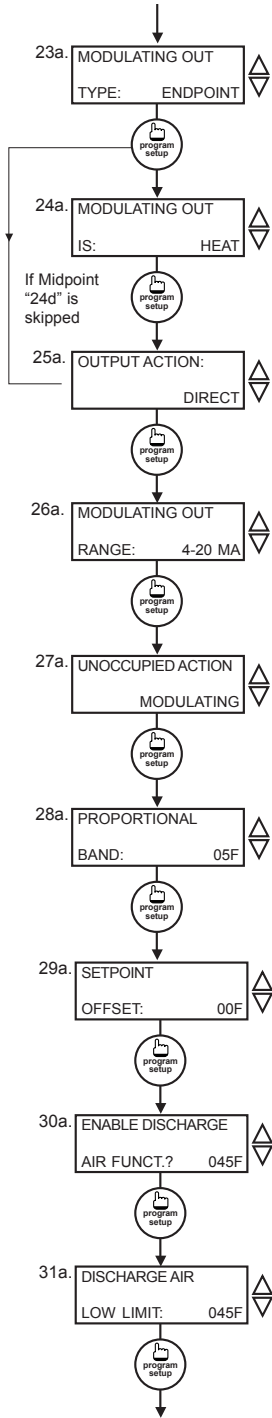

Modulating Output Type Screen.
Choose whether the modulating output will use Endpoint or Midpoint Control.

Modulating Output Define Screen.
Choose whether the modulating output will be used for COOL, HEAT or AQUASTAT. With DI2 set to AQUASTAT, the analog output will be used for cooling with DI2 open and heating with DI2 closed.

Modulating Output Action Screen.
Choose whether the output will be direct or reverse acting. (When DI2 is set to AQUASTAT, the output will automatically reverse action when DI2 is closed.)

Modulating Output Range Screen.
Choose whether the modulating output range will be 0-20 mA or 4-20 mA.

Unoccupied Action Screen. Choose whether the unoccupied action will be modulating, 0 mA, 4 mA, or 20 mA.

Modulating Output Proportional Band Screen. Enter the number of degrees away from the setpoint that the valve or damper will be fully open.

Analog Output Setpoint Offset Screen. Enter a setpoint offset. This is a value below the heating setpoint or above the cooling setpoint where the analog output begins to modulate.

Discharge Air Sensor Function Screen. Choose whether or not you are using a discharge air sensor function. To monitor only, select NO. See setup instructions for dipswitch settings which must also be set.

Discharge Air Low Limit Screen. Enter a discharge air low limit value. This screen will not appear if the discharge air sensor function is disabled.

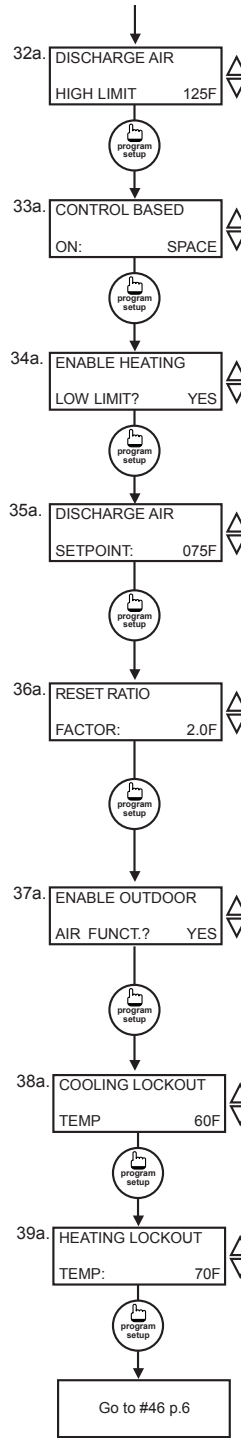

Discharge Air High Limit Screen.
Enter a discharge air high limit value. This screen will not appear if the discharge air sensor function is disabled.

Discharge Air Reset Screen.
Choose whether to control based on DISCHARGE air reset or SPACE temperature. This screen will not appear if the discharge air sensor function is disabled.

Discharge Air Enable Heating Low Limit Screen. Choose whether to enable Heating Low temperature Limit. This screen will not appear if the control is based on space temperature.

Discharge Air Setpoint Screen. Enter a value at which the discharge air setpoint is to be controlled. This screen will not appear if the control is based on space temperature or if heating low limit is disabled.

Reset Ratio Factor Screen. Enter a reset ratio factor. This is the number of degrees that the discharge air setpoint is raised when the space temperature falls by 1 degree for heating, or the number of degrees that the discharge air setpoint is lowered when the space temperature rises by 1 degree for cooling.

Outdoor Air Sensor Function Screen. Choose whether or not you are using an outdoor air sensor function. To monitor only, select NO. See setup instructions for dipswitch settings which must also be set.

Cooling Lockout Screen. Enter an outdoor air cooling lockout temperature. This screen will not appear if the outdoor air sensor function is disabled.

Heating Lockout Screen. Enter an outdoor air heating lockout temperature. This screen will not appear if the outdoor air sensor function is disabled.

SZ1041 Programming Sequences

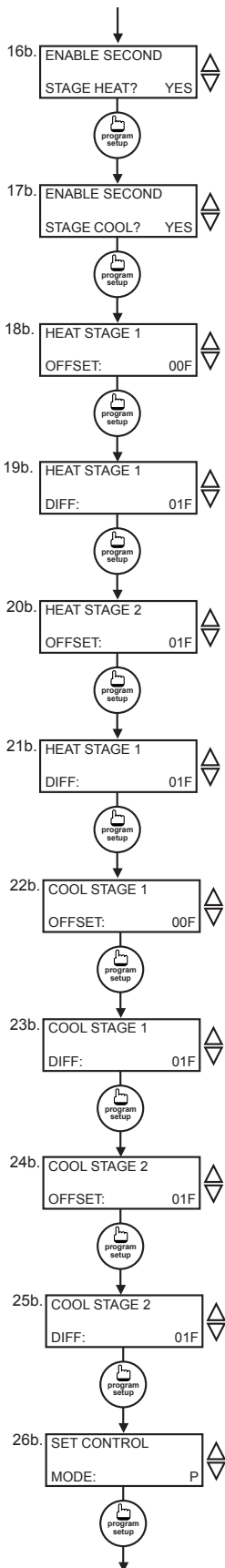

Second Stage Heat Screen. Indicate whether the thermostat will control a second stage of heating. (Select NO if not using a second stage of heating.)

Second Stage Cool Screen. Choose whether the thermostat will control a second stage of cooling. (Select NO if not using a second stage of cooling.)

Heat Stage 1 Offset Screen. Enter an offset value for heat stage 1. First stage is normally 0 offset.

Heat Stage 1 Differential Screen. Enter a differential value for heat stage 1.

Heat Stage 2 Offset Screen. Enter an offset value for heat stage 2. This screen only appears if stage 2 is enabled.

Heat Stage 2 Differential Screen. Enter a differential value for heat stage 2. This screen only appears if stage 2 is enabled.

Cool Stage 1 Offset Screen. Enter an offset value for cool stage 1. First stage is normally 0 offset.

Cool Stage 1 Differential Screen. Enter a differential value for cool stage 1.

Cool Stage 2 Offset Screen. Enter an offset value for cool stage 2. This screen only appears if stage 2 is enabled.

Cool Stage 2 Differential Screen. Enter a differential value for cool stage 2. This screen only appears if stage 2 is enabled.

Control Mode Screen. Enter whether you want to control by temperature only (P) or add a time factor (P+I). This applies to the stage outputs only.

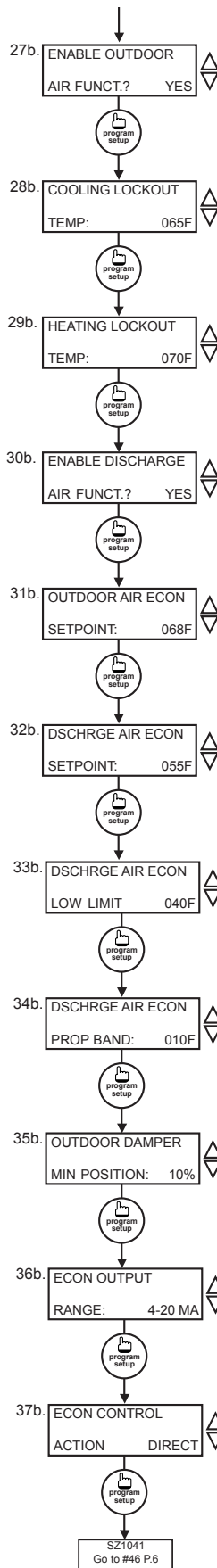

Outdoor Air Sensor Function Screen. Choose whether or not you are using an outdoor air sensor function. To monitor only, select NO. See setup instructions for dip-switch settings which must also be set.

Cooling Lockout Screen. Enter an outdoor air cooling lockout temperature. This screen will not appear if the outdoor air sensor function is disabled.

Heating Lockout Screen. Enter an outdoor air heating lockout temperature. This screen will not appear if the outdoor air sensor function is disabled.

Discharge Air Sensor Function Screen. Choose whether or not you are using a discharge air sensor function. To monitor only, select NO. See setup instructions for dip-switch settings which must also be set.

Outdoor Air Economizer Screen. Set the outdoor air setpoint. This screen will not appear if the discharge air sensor function is disabled.

Discharge Air Economizer Screen. Set the discharge air setpoint. This screen will not appear if the discharge air sensor function is disabled.

Discharge Air Low Limit Screen. Enter a discharge air low limit value. This screen will not appear if the discharge air sensor function is disabled.

Economizer Proportional Band Screen. Set the discharge air proportional band or throttling range. This screen will not appear if the discharge air sensor function is disabled.

Outdoor Damper Min. Position Screen. Set the minimum damper position. This screen will not appear if the discharge air sensor function is disabled.

Economizer Output Screen. Choose whether the modulating output range will be 0-20 mA or 4-20 mA. This screen will not appear if the discharge air sensor function is disabled.

Economizer Control Action Screen. Choose whether the economizer control action will be direct or reverse acting. This screen will not appear if the discharge air sensor function is disabled.

SZ1051 Programming Sequences

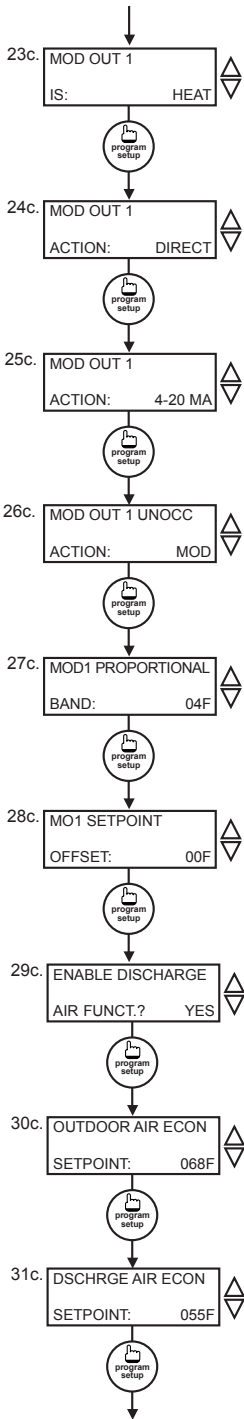

Modulating Output 1 Define Screen. Choose whether the modulating output will be used for COOL, HEAT or AQUASTAT. With DI2 set to AQUASTAT, analog output one will be used for cooling with DI2 open and heating with DI2 closed.

Modulating Output 1 Action Screen. Choose whether the output will be direct or reverse acting. (When DI2 is set to AQUASTAT, the output will automatically reverse action when DI2 is closed.)

Modulating Output 1 Range Screen. Choose whether the modulating output one range will be 0-20 mA or 4-20 mA.

Modulating Output 1 Unoccupied Action Screen. Choose whether the unoccupied action will be modulating, 0 mA, 4 mA, or 20 mA.

Modulating Output 1 Proportional Band Screen. Enter the number of degrees away from the setpoint that the heating or cooling device will be fully open.

Modulating Output 1 Setpoint Offset Screen. Enter a setpoint offset. This is a value below the heating setpoint or above the cooling setpoint where analog output one begins to modulate.

Discharge Air Sensor Function Screen. Choose whether or not you are using a discharge air sensor function. To monitor only, select NO. See setup instructions for dipswitch settings which must also be set.

Outdoor Air Economizer Screen. Set the outdoor air setpoint. This screen will not appear if the discharge air sensor function is disabled.

Discharge Air Economizer Screen. Set the discharge air setpoint. This screen will not appear if the discharge air sensor function is disabled.

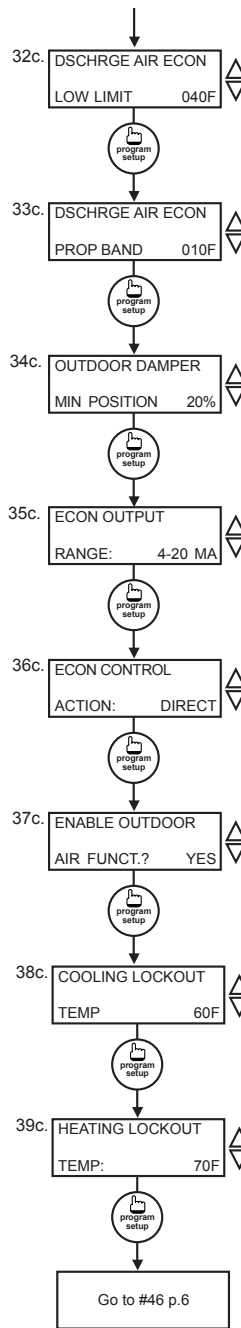

Discharge Air Low Limit Screen. Enter a discharge air low limit value. This screen will not appear if the discharge air sensor function is disabled.

Economizer Proportional Band Screen. Set the discharge air proportional band or throttling range. This screen will not appear if the discharge air sensor function is disabled.

Outdoor Damper Min. Position Screen. Set the minimum damper position. This screen will not appear if the discharge air sensor function is disabled.

Economizer Output Range Screen. Choose whether the modulating output two range will be 0-20 mA or 4-20 mA. This screen will not appear if the discharge air sensor function is disabled.

Economizer Control Action Screen. Choose whether the economizer control action will be direct or reverse acting. This screen will not appear if the discharge air sensor function is disabled.

Outdoor Air Sensor Function Screen. Choose whether or not you are using an outdoor air sensor function. To monitor only, select NO. See setup instructions for dipswitch settings which must also be set.

Cooling Lockout Screen. Enter an outdoor air cooling lockout temperature. This screen will not appear if the outdoor air sensor function is disabled.

Heating Lockout Screen. Enter an outdoor air heating lockout temperature. This screen will not appear if the outdoor air sensor function is disabled.

SZ1053 Programming Sequences

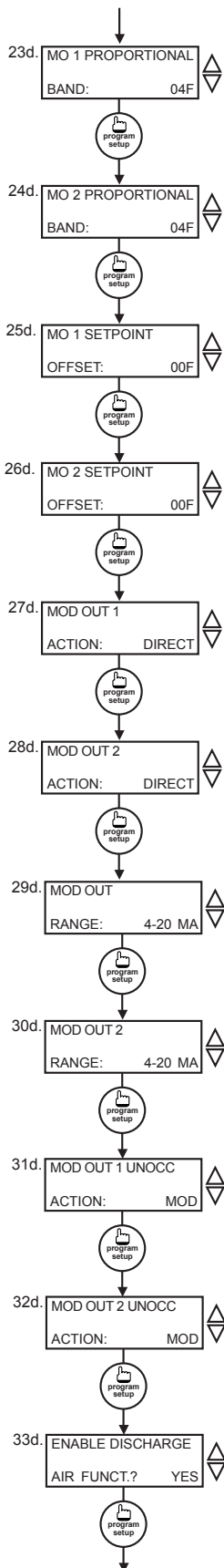

Modulating Output 1 Proportional Band Screen. Enter the number of degrees away from the heating setpoint that the valve or damper will be fully open.

Modulating Output 2 Proportional Band Screen. Enter the number of degrees away from the cooling setpoint that the valve or damper will be fully open.

Modulating 1 Setpoint Offset Screen. Enter an offset value for modulating output 1. This is the number of degrees below the heating setpoint before the output begins to modulate.

Modulating 2 Setpoint Offset Screen. Enter an offset value for modulating output 2. This is the number of degrees above the cooling setpoint before the output begins to modulate.

Modulating 1 Output Action Screen. Choose whether modulating output 1 will be direct or reverse acting.

Modulating 2 Output Action Screen. Choose whether modulating output 2 will be direct or reverse acting.

Modulating Output 1 Range Screen. Choose whether the modulating output 1 range will be 0-20 mA or 4-20 mA.

Modulating Output 2 Range Screen. Choose whether the modulating output 2 range will be 0-20 mA or 4-20 mA.

Modulating Output 1 Unoccupied Action Screen. Choose whether the modulating output 1 unoccupied action will be 0mA, 4mA, 20mA or MODulating.

Modulating Output 2 Unoccupied Action Screen. Choose whether the modulating output 2 unoccupied action will be 0mA, 4mA, 20mA or MODulating.

Discharge Air Sensor Function Screen. Choose whether or not you are using a discharge air sensor function. To monitor only, select NO. See setup instructions for dip-switch settings which must also be set.

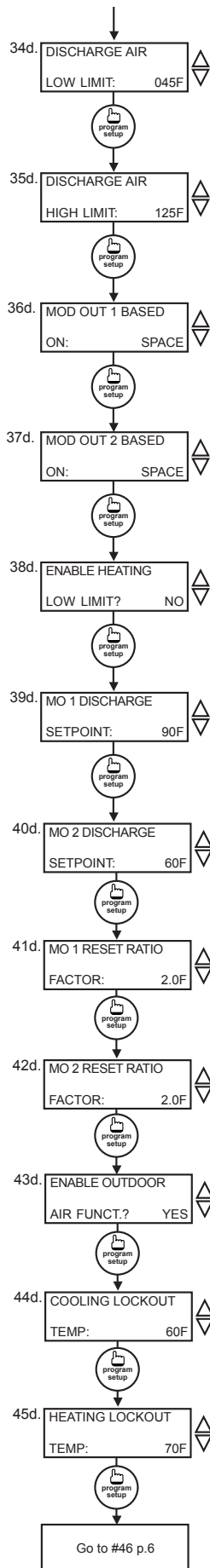

Discharge Air Low Limit Screen. Enter a discharge air low limit value. This screen will not appear if the discharge air sensor function is disabled.

Discharge Air High Limit Screen. Enter a discharge air high limit value. This screen will not appear if the discharge air sensor function is disabled.

Modulating Output 1 Control Screen. Choose whether to control based on DISCHARGE air reset or SPACE temperature.

Modulating Output 2 Control Screen. Choose whether to control based on DISCHARGE air reset or SPACE temperature.

Modulating Output Enable Heating Low Limit Screen. Choose whether to enable Heating Low Limit.

Modulating Output 1 Discharge Air Setpoint Screen. Enter a value at which the discharge air setpoint is to be controlled for heating.

Modulating Output 2 Discharge Air Setpoint Screen. Enter a value at which the discharge air setpoint is to be controlled for cooling.

Modulating Output 1 Reset Ratio Factor Screen. Enter a reset ratio factor. This is the number of degrees that the discharge air setpoint is raised when the space temperature falls by 1 degree.

Modulating Output 2 Reset Ratio Factor Screen. Enter a reset ratio factor. This is the number of degrees that the discharge air setpoint is lowered when the space temperature rises by 1 degree.

Outdoor Air Sensor Function Screen. Choose whether or not you are using an outdoor air sensor function. To monitor only, select NO. See setup instructions for dipswitch settings which must also be set.

Cooling Lockout Screen. Enter an outdoor air cooling lockout temperature. This screen will not appear if the outdoor air sensor function is disabled.

Heating Lockout Screen. Enter an outdoor air heating lockout temperature. This screen will not appear if the outdoor air sensor function is disabled.

Setting Clock & Schedule

The SZ1017a, SZ1041, SZ1051, and SZ1053 clock and schedule may be set through the keypad and display, or with a PC. For more information on programming through the PC, consult your TCS software manual.

SETTING CLOCK & SCHEDULE THROUGH THE KEYPAD

To access the clock and schedule screens, press the clock setup button. To make changes, use the warmer and cooler keys. For screens that have more than one field to set, use the override key to move to the next field. Access may be locked out with dipswitches, or an access code may be required.



MON 08-08-08
12:00AM 72F

Main Monitoring Screen. Press the clock setup button to access the following screens. (Date not shown on SZ1017a.)

1. ENTER ACCESS
CODE 000

Access Code Entry Screen. May appear if access code is required for setting clock and schedules. Use 248 as the default. If the wrong code is entered, it will revert to the previous screen.

2. SET TIME & DAY:
12:00 AM MON

Time and Day Screen. Set the hour, minutes, AM or PM, and day of the week.

3. SET DATE:
08-08-08

Date Screen. Set the month, date, and year. (This screen not shown on SZ1017a.)

4. SET OCCUPIED
TIMES MONDAY:

Schedule Announcement Screen. Announces the next screen.

5. A:08:00 TO 17:00
B:00:00 TO 00:00

Occupied Times Screen. Set hours and minutes of start and end times for up to two occupied periods.

6. C:00:00 TO 00:00
D:00:00 TO 00:00

Occupied Times Screen. Set hours and minutes of start and end times for up to two occupied periods.

The following screens are repeated for Wed., Thurs., Fri., Sat., and Sun., Holiday #1 and #2

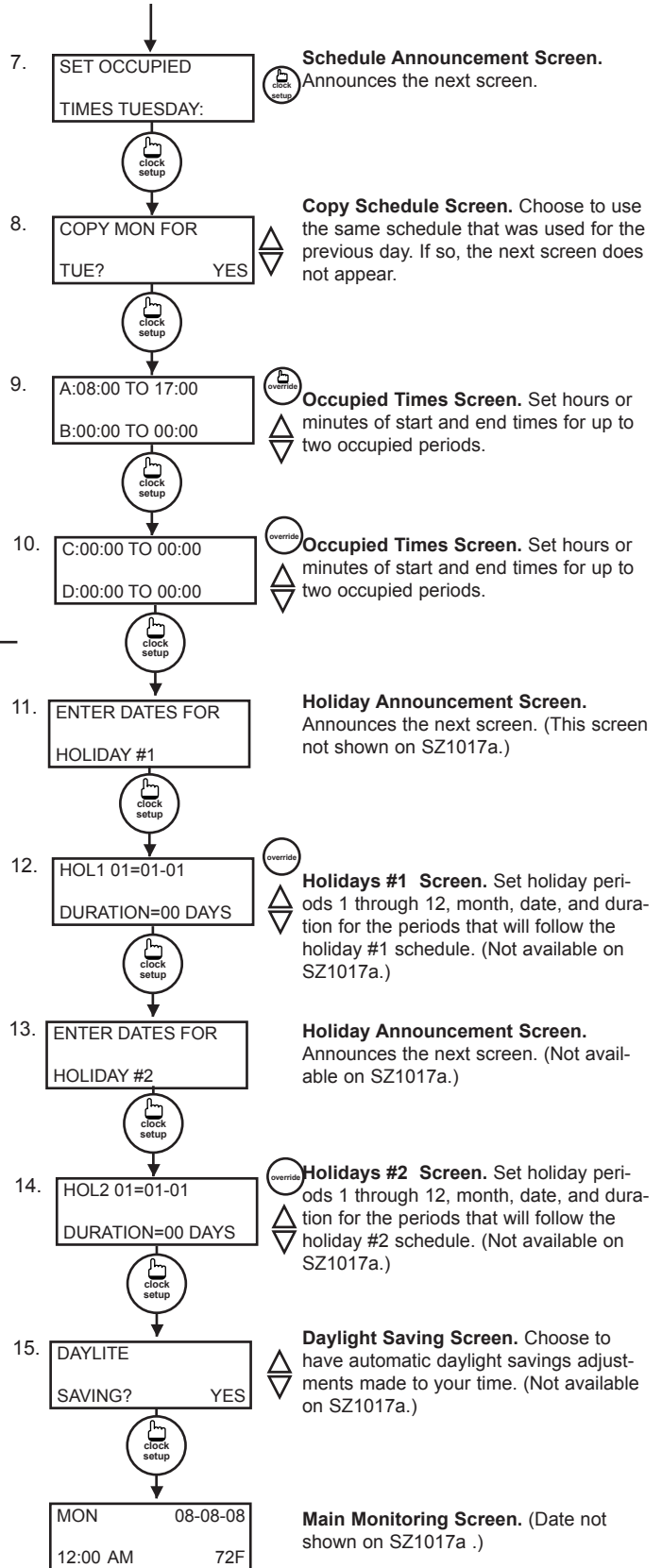

Operation

UNOCCUPIED SETBACK

The SZ1017a, SZ1041, SZ1051, and SZ1053 operate in either an occupied or unoccupied mode. During the occupied mode, the occupied heating and cooling setpoints will be maintained, and the fan will operate according to its occupied setting. During the unoccupied mode, the unoccupied heating and cooling setpoints will be maintained, and the fan will operate according to its unoccupied setting. The occupied LED will be lit when the unit is operating in the occupied mode.

The occupied schedule may be set utilizing the internal time clock or DI3 may be used with an external time clock, whereas when DI3 is closed, the unit is in the occupied mode. The Smart Recovery function is disabled when DI3 is used for external time clock.

OVERRIDE

A timed override is available using the button on the face of the thermostat or through momentary contacts wired into the OVR terminal. The amount of time the unit will be overridden is set from 0 to 255 minutes in the programming screen. This override behaves differently depending on the mode the thermostat is operating in (occupied or unoccupied) and the options that have been enabled within the software.

In standard mode, the override only activates in unoccupied mode and takes the thermostat into occupied mode. If "Override for Occupied Period" is enabled using the software, the override also activates in occupied mode and takes the thermostat into unoccupied mode. In either case, you are able to view the time remaining in the override period both within the software and by using the service button to scroll through the status screens. If the occupant desires to return the thermostat to unoccupied or occupied operation (depending on how the override was used) before the override time remaining elapses, they may press the override button again.

Additionally, an "Override Hold" feature is built into the thermostats. When in unoccupied mode, pressing the override once and then pressing/holding it for 5 seconds puts the thermostat into a "hold" mode (the override LED on the thermostat will flash quickly to confirm the mode change). In this mode, the override setpoints are used until the next occupied period is reached or until the thermostat is manually taken out of the "hold" mode by pressing the override button again. This feature also works when the "Override for Occupied Period" is enabled BUT starting from the occupied mode and holding the thermostat in the unoccupied state.

A continuous override is available through the DI3 contact or the software. If DI3 is set to external override, the unit will be in the occupied mode whenever the DI3 contact is closed. When using this option, the timed override may still be activated.

SETBACK AND OVERRIDE APPLICATIONS

In most applications, it is desired to maintain a regular schedule, and allow timed override with the button on the face or with a remote momentary contact.

To allow a regular schedule, and also automatically override with the use of occupancy or light sensor, set DI3 to override and set it up so that the contact is closed when you want the override.

For applications where a room might not be used on a regular schedule, such as conference rooms, set DI3 to external time clock and close the contact when you want the room occupied, such as with a switch or wind-up timer. If each occupancy period is about the same, (theaters, meetings) another option is to set the DI3 to external time clock, and use the timed override button to put the unit in occupied mode.

To make the unit always occupied, set DI3 to external time clock and short the DI3 terminal to ground.

DISCHARGE AIR TEMPERATURE SENSING

The SZ1017a, SZ1041, SZ1051, and SZ1053 accept a remote discharge air sensor for monitoring purposes. (See setup instructions for dipswitch placement for this option.)

SZ1041 and SZ1051

Choose YES in programming screen #30b (for the SZ1041) or #29a (for the SZ1051) only if you have a discharge air sensor installed and you want the SZ1041 or SZ1051 use its built-in economizer functions. If NO is chosen, the discharge air is still monitored. You must also have an outdoor air sensor installed for economizer operation. See Economizer Operation section for further programming options.

SZ1017a and SZ1053

Choose YES in programming screen #30d (for the SZ1017a) or #33c (for the SZ1053) only if you are using a discharge air sensor and you want to enable the discharge air temperature high and low limit functions or discharge air reset function. See Discharge Air Reset section for further programming options. If NO is chosen, the discharge air is still monitored.

When this function is enabled, a LOW LIMIT and HIGH LIMIT are entered in steps #31d and #32d (SZ1017a) or #34c and #35c (SZ1053). If the HIGH LIMIT is reached, the fan and heating devices will be turned off and will remain off until the discharge air temperature falls 3° below that limit. If the LOW LIMIT is reached, the fan and cooling devices will be turned off and will remain off until the discharge air temperature rises 3° above that limit. When either limit is reached, the service LED will be on until normal operation resumes.

The discharge air span is 0 to 150°F (-17.8 to 65.6°C).

ANALOG OUTPUTS (SZ1041 and SZ1051)

On the SZ1041, analog output one is used to control an economizer. On the SZ1051 and analog output one is used to control the heating or cooling in a space, while analog output two is used to control an economizer.

ANALOG OUTPUTS/DISCHARGE AIR RESET (SZ1017a, and SZ1053)

The analog output on the SZ1017a is used to control the heating or cooling in a space. The analog outputs on the SZ1053 are used to control the heating and cooling in a space. To use the discharge air reset function, a discharge air sensor must be installed. In programming step #30d (for the SZ1017a) or #33c (for the SZ1053) the discharge air sensor must be enabled. In programming step #33d (SZ1017a), or #36c and/or #37c (SZ1053), the control must be based on DISCHARGE air.

In programming screen #34d (SZ1017a) or #38c (SZ1053) re will be controlled to this setting by modulating the heating or cooling device.

In programming screen #36d (SZ1017a), you are asked to enter a reset ratio factor. This is the number of degrees that the discharge air setpoint is raised when the room temperature falls below the heating setpoint by 1 degree if the analog output is set for heating, or the number of degrees that the discharge air setpoint is lowered when the room temperature rises above the cooling setpoint by 1 degree if the analog output is set for cooling.

OUTDOOR AIR TEMPERATURE SENSING

The SZ1017a, SZ1041, SZ1051, and SZ1053 accepts a remote outdoor temperature sensor for monitoring purposes. (See setup instructions for dipswitch placement for this option.)

Choose YES in programming screen #37d (for the SZ1017a) or #27b (SZ1041) or #37a (SZ1041) or #43c (SZ1053) only if you are using an outdoor air sensor and you want to enable the outdoor air heating and cooling lockout functions. If NO is chosen, the outdoor air is still monitored.

When the function is enabled, COOLING LOCKOUT TEMP and HEATING LOCKOUT TEMP are entered in steps #37d and #38d (for the SZ1017a) or #28b and #29b (SZ1041) or #38a and #39a (SZ1051) or #44c and #45c (SZ1053). If the outdoor air temperature falls below the COOLING LOCKOUT TEMP, all cooling stages will be locked out and will remain locked out until the outdoor air temperature rises 2° above the lockout temperature. If the outdoor air temperature rises above the HEATING LOCKOUT TEMP, all heating stages will be locked out and will remain locked out until the outdoor air temperature falls 2° below the lockout temperature.

The outdoor air span is -40 to 160 °F (-40.0 to 71.1 °C).

FAN PROVING

The SZ1017a, SZ1041, SZ1051, and SZ1053 allow DI1 to be set for fan proving to protect equipment on fan failure. To utilize this, a pressure or current switch is required, which indicates when the fan is running. If the thermostat turns on the FAN, and DI1 is not closed after thirty seconds, the system will go to OFF, disabling all outputs, the fan LED will turn off and the service LED will be lit until the system is manually reset by switching the system to a mode other than OFF.

DI2 SETPOINT SHIFT

The SZ1017a, SZ1041, SZ1051, and SZ1053 allow DI2 to be set for setpoint shift for energy demand setback. This is enabled by setting DI2 to the MONITOR mode. A digital contact that closes when setback is needed should be wired into DI2. You may specify a number of degrees such that, when the thermostat is operating in the occupied mode, and DI2 is closed, the heating setpoint will be lowered this number of degrees, and the cooling setpoint will be raised this number of degrees. The fan will continue to operate according to its occupied setting. If you are using DI2 as monitor for another purpose, make sure to set the setpoint shift value to zero.

STAGE OUTPUT PARAMETERS

The SZ1017a, SZ1051, and SZ1053 will control up to two stages of either heating or cooling. The SZ1041 will control two stages of heating and two stages of cooling.

For each stage, you may specify an offset and a differential value. The offset value is the amount away from the setpoint a stage will turn off. By assigning a stage a value other than zero, you "anticipate" that the residual heat or cooling in the duct or the other stages will bring the temperature back to setpoint. In most cases, the first stage is set to zero. The differential value is the difference between the on and off points.

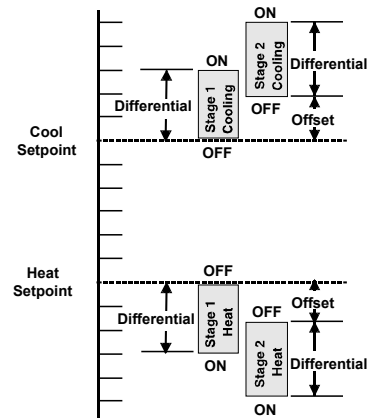

Unlike most other multi-stage programmable thermostats, the Superstat allows independent adjustments of "offsets" and "differentials" for stages of heating and cooling. The offset settings can be viewed as setpoints for the second and third stages and are programmed in the Superstat in the number of degrees (i.e. 1,2,3...) beyond the heating and cooling setpoints (temperatures to be maintained).

The differential for each stage can be viewed as the "anticipator" function used in mechanical thermostats.

P+I OPTION

The SZ1017a, SZ1041, SZ1051, and SZ1053 also have a P+I option. Without enabling this option, stages turn on and off based on temperature vs. setpoint alone, as described above. By enabling this option, you add a time factor to anticipate heating and cooling.

ANALOG OUTPUT PARAMETERS

Use programming steps #23d through #29d (for the SZ1017a) or #23a through #28a (for the SZ1051) or #23c through #32c (SZ1053) to program the operating parameters for the analog output. Select whether the analog output is set for heating, cooling or aquastat (SZ1017a and SZ1051). Select direct or reverse action. Select whether you want the analog output to modulate from 4 to 20mA or 0 to 20mA. Select the unoccupied action ("20mA or 0 / 4mA" will hold the analog output device open or closed during unoccupied times. "Modulating" will modulate the analog output device to maintain the unoccupied heating or cooling setpoint.) Enter a proportional band (throttling range) in degrees. Enter a setpoint offset in degrees. (This is a value below the heating setpoint or above the cooling setpoint where the analog output begins to modulate.)

ECONOMIZER OPERATION

The analog output on the SZ1041 and analog output two on the SZ1051 are used to control an economizer. Both outdoor air and discharge air temperature sensors are needed to accomplish this.

NOTE: The discharge air sensor may be installed in the discharge air section or in the mixed air section. This instruction as well as product literature refers to a discharge air sensor, regardless of where it is mounted.

During occupied time, the outside air dampers are held at a minimum position, entered in programming step #35b (for the SZ1041) or #34a (for the SZ1051), until economizer operation is enabled. During unoccupied time, the outside air dampers are closed.

In programming screen #31b (SZ1041) or #30a (SZ1051), you are asked to enter an outdoor air setpoint. The outdoor air temperature must fall below this setpoint before economizer operation will be enabled. A call for cooling is also required to enable economizer operation. A typical value is 65°F.

In programming screen #32b (SZ1041) or #31a (SZ1051), you are asked to enter a discharge air setpoint. The discharge air temperature will be controlled to this setting by modulating the outdoor air dampers, when economizer operation is enabled. In programming screen #33b (SZ1041) or #32a (SZ1051), you are asked to enter a discharge air low limit setpoint. If the discharge air falls to this setpoint, the outside air dampers will close.

A proportional band (throttling range), whether you want the analog output to modulate from 4 to 20mA or 0 to 20mA, and direct or reverse action must also be programmed.

DI2 ECONOMIZER ENABLE (SZ1041)

When DI2 is selected to use the economizer function the Outdoor Air Economizer setpoint is NOT USED, instead the thermostat operates as follows. With DI2 "Open", the economizer function is OFF and AO1 goes to the minimum position. When DI2 is "Closed", the economizer function is ON.

DI2 AQUASTAT (SZ1017a and SZ1051)

When DI2 is selected to have an aquastat function, and analog output one is selected to have an aquastat function, operation is as follows. With DI2 "Open", the analog output operates in cooling mode, and uses selected direct or reverse action. When DI2 is "Closed", the analog output operates in heating mode, and uses the opposite of the selected direct or reverse action.

SMART RECOVERY

"Smart Recovery" may be enabled. It ramps the setpoint 4°F/hr. when going from the unoccupied mode to the occupied mode. At the beginning of the occupied mode, the occupied setpoint will be reached, many times without the need for the second stage to come on. This feature is automatically disabled when DI3 is set to external time clock.

AUXILIARY OUTPUT

An auxiliary relay output is available to output a signal based on the occupancy status. It is commonly used with an economizer minimum position control, or to signal an outdoor air damper to open in occupied times in lieu of an economizer. It may also be used for lighting or hot water heaters. Keep in mind that although it is an isolated relay (separate common terminal), it is rated at 24 VAC. For loads that exceed this, use an external relay. It may be set to be open (NO) or closed (NC) when the thermostat is operating in the occupied mode, and will be the oppo-

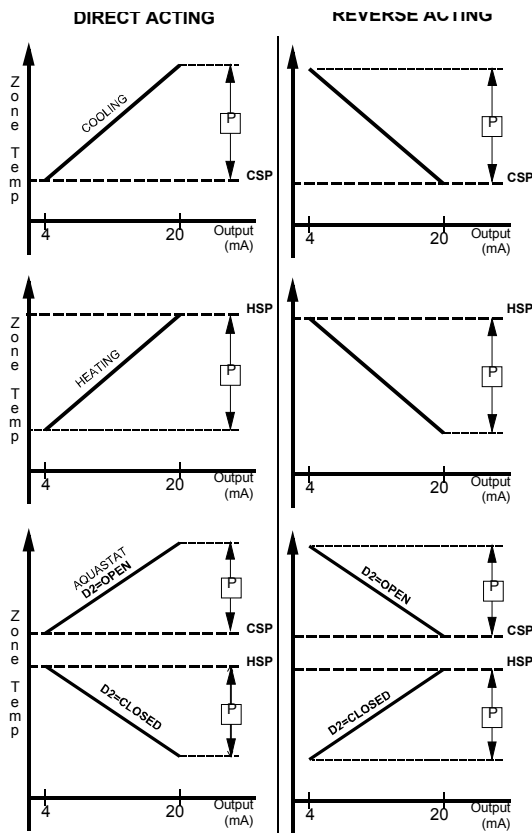

Digital Input Summary Table

DIGITAL INPUT	APPLICATION	LED INDICATION?	SERVICE SCREEN (DI STATUS SCREEN)	CONTROL PROVIDED	SENSOR OR DEVICE NEEDED
DI1	Fan Proving	YES	CHECK FAN, FAN OK or FAIL	YES - turns system mode to "off" — requires manual re-start (set system to auto)	Differential pressure or current switch
DI1	Equipment Monitoring	NO	OK (DI1 OPEN or CLOSED)	NO	Dry contact, switch. Any type for monitoring and indication
DI2	Service Alert	YES (DI2 SERVICE OFF or ON)	OK or CHECK DI2	NO for monitoring and indication	Dry contact, switch. Any type
DI2	Monitor with setpoint shift	NO	OK (DI2 OPEN or CLOSED)	YES - shifts setpoint by programmed amount	Dry contact, switch
DI2	Cooling Lockout	NO	OK (COOL LOCKOUT ON or OFF)	YES - locks out 2nd and 3rd stage cooling	Dry contact, switch
DI2	Economizer (SZ1041 ONLY)	NO	OK (Shows ECON ON or OFF)	YES, limits AO1 to min position when ECON OFF	Enthalpy sensor, switch
DI3	Filter Service	YES	OK or CHECK FILTER (FILTER OK or CHECK)	NO	Differential pressure switch
DI3	External Occupancy Override	NO	OK (EXT OVER ON or OFF)	YES - switches to occupied mode as long as contact is made*	Dry contact such as twist timer, light switch, etc.
DI3	External Time Clock Input	NO YES Occupied?	OK (EXT TIMECLOCK ON or OFF)	YES -input overrides thermostat occupancy program	Dry contact; external time clock (TCS part SL1001a)

*See delay on occupied.

site during the unoccupied mode.

BUILT-IN DELAYS

The SZ1017a, SZ1041, SZ1051, and SZ1053 have delays built into the programming sequences to protect equipment. The fan has a minimum on and off time of 30 seconds. When the fan is in AUTO or COOL mode, it will come on 30 seconds before the heating or cooling devices are allowed to sequence on, and remain on for 2 minutes after the heating or cooling devices sequence off. Each stage has a minimum on and off time of two minutes. There is a minimum of 2 minutes between when one stage turns on until the next stage is allowed to turn on, as well as when one stage turns off until the next stage is allowed to turn off.

Delay on occupied, see delay on powerup.

DELAY ON POWERUP

The SZ1017a, SZ1041, SZ1051, and SZ1053 have an adjustable delay on powerup. When several thermostats are used at one location, and the power goes out, most thermostats turn all of the units back on at the same time on regain of power, creating a peak. The thermostat allows you to set a value, in seconds, where no outputs are allowed to turn on for that length of time on powerup. Setting each unit to a different delay allows

you to soft start your system, and thus prevent this peak. This delay can also be applied to the start of occupied time.**DAYLIGHT SAVING TIME**

Beginning in 2007, Daylight Saving Time (DST) in the U.S. will be extended by having an earlier change to DST in spring and a delay in switching back to standard time in fall. However, this change may only be temporary, as this "new" schedule is only in effect for a 2 year trial period. After that, the DST schedule may revert back, stay the same, or be something completely different. Products shipped starting in 2007 with firmware version 1.5 or higher accommodate the new DST schedule. Products shipped starting in 2008 with firmware version 2.0 or higher accommodate the new DST schedule and have the ability to be programmed to accommodate any future schedules that may be used. Should the schedule change and you need to customer program the DST start and end dates, simply enable the "Daylight Saving Time" option within the software and enter the starting month + week and the ending month + week.

Checkout & Troubleshooting

CHECKOUT

NOTE: The fan has a minimum on and off time of 30 seconds. The heating and cooling stages have a minimum on and off time of 2 minutes.

You may verify the status of heating and cooling and fan in monitoring screens 5, 6, and 7, which are accessed by pressing the SERVICE STATUS button.

1. Verify all wiring prior to powering the thermostat.
2. Turn power on. The thermostat will display a momentary screen with the model number, and then the main monitoring screen with the time, day, date (SZ1041, SZ1051, and SZ1053 only) and current temperature.
3. Press the PROGRAM SETUP button until you reach the screen # 14 which allows you to set the occupant setpoint adjustment limits. Change this to +/-20 °F (11.1 °C). Press the PROGRAM SETUP button once more to store the change. Then press the SERVICE

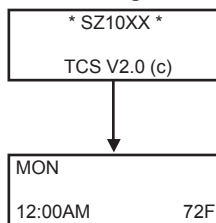

STATUS button once to exit the programming.

4. Press the FAN SWITCH button to access the fan mode and change the mode to AUTO. Press the FAN SWITCH button once more to store the change. Press the SYSTEM SWITCH button to access the system mode and change the mode to AUTO. Press the SYSTEM SWITCH button once more to store the change.
5. Verify that the thermostat is operating in the occupied mode by making sure that the top LED is lit. If not, press the OVERRIDE button. The LED should light up.

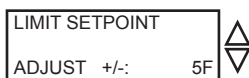

6. Take note of the current temperature reading. Press the WARMER (up) button. The setpoint adjustment screen should now be showing. Press the WARMER button until the heating setpoint is greater than the current temperature by at least five degrees. The fan will come on. The heating stage(s) will sequence on after 30 seconds.
7. Press the cooler (down) button until the heating setpoint is one degree less than the current temperature. The heating stage(s) will sequence off. The fan will turn off 2 minutes after the last heating stage.
8. Press the cooler button until the cooling setpoint is less than the current temperature by at least five degrees. The fan will come on. The cooling stage(s) will

sequence on after 2 minutes.

9. Press the warmer button until the cooling setpoint is greater than the current temperature by one degree. The cooling stage(s) will sequence off. The fan will turn off 2 minutes after the last cooling stage.
10. For a heating or cooling analog output: Take note of the room (and discharge) air temperatures. If the analog output is set for Cooling, press the Cooler button until the cooling setpoint is less than the current room temperature by at least 5°. The cooling device should start operating. If the analog output is set for Heating, press the Warmer button until the heating setpoint is greater than the current room temperature by at least 5°. The heating device should start operating.
11. For an economizer analog output: Take note of the discharge and outdoor air temperatures. Go to programming step #30a (for the SZ1051) or #31b (for the SZ1041) and set the outdoor air setpoint 5° greater than the outdoor air temperature. Go to programming step #32b (for the SZ1041) or #31a (for the SZ1051) and set the discharge air setpoint 10° less than the discharge air temperature. Press the Cooler button until the cooling setpoint is less than the current room temperature by at least 5°. The damper should now be fully open. Raising the discharge air setpoint, will modulate the damper closed. Raising the cooling setpoint above the room temperature or lowering the outdoor air setpoint below the outdoor air temperature will shut the damper to minimum position.
12. Go back to programming step #14 and set the setpoint adjust limit back to the desired value. Make any other changes in programming, clock, and schedule. Set the fan and system modes to their desired settings.
13. If using remote sensor(s), verify that the reading is correct. If not, see *Wrong Temperature Display* in **Troubleshooting** section.

TROUBLESHOOTING

No Display

Check for 24 VAC on terminals "+24" and "-24". Check the cable connecting the cover to the base for a good connection.

Fan Does Not Come On

The fan is on whenever the fan LED is on. If the fan should be on, but the fan LED is off, check the fan and system switch modes, and the unoccupied fan mode in programming. If the fan is off but the fan LED is on, check wiring. Short terminals "R" to "G" and see if the fan comes on. This is a check for a mechanical relay failure.

Heating or Cooling Does Not Come On

At least one stage of heating is on whenever the heating LED is on, and at least one stage of cooling is on whenever the cooling LED is on. If heating or cooling

should be on but the heating or cooling LED is off, check the fan and system switch modes. Also, check the heating and cooling setpoints, offsets and differentials, and the room temperature to be sure heating or cooling should be on. If using outdoor air heating and cooling lockouts, or discharge air high and low limits, check their values to be sure heating or cooling is allowed. If heating or cooling is off, but the corresponding LED is on, check the wiring. Short terminals "R" to "Y/W1" or "Y/W2" and see if the heating or cooling comes on. This is a check for a mechanical relay failure.

Wrong Temperature Display

Initially, verify the wiring connections to check for problems (poor connections, opens, or shorts). If the temperature is at a minimum or maximum reading, check that the sensor dipswitch positions are correct as shown in the Setup section of this document. Also, verify the resistance reading for the sensor in question. A remote sensor should read 1080 to 1090 ohms at room temperature. The built-in sensor should read 108 to 109 ohms at room temperature. If any of the temperatures are still reading slightly high or low, you can add in a temperature offset (calibration) using Ubiquity or TCS Insight. In Ubiquity, you can edit the calibration offset for each temperature input (room, discharge, outdoor air, etc.) on the controller's programming page. For example, if the room temperature is reading 2 degrees high, you would subtract 2 from the existing offset in the room temperature calibration offset field and submit the page. In TCS Insight, the process is similar. Refer to the Calibrate Using TCS Insight Tech Bulletin # 1019 for details. As a last resort and only when directed to do so by TCS technical support, you may be able to use the on-board adjustment pots. Refer to the Thermostat Sensor Calibration Tech Bulletin # 1005 for details.

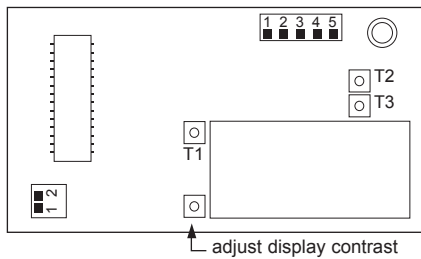

Service LED is On

If the service LED is on, it may be for monitoring purposes or it may indicate a critical problem. The first monitoring screen accessed by pressing the service status button will display why the light is on.

Outputs Will Not Shut Off

First check the room temperature and the setpoints and determine whether the output should be on. There are delays and minimum on and off times for the fan and heating and cooling stages. Also, check the service status menus to verify that the outputs are on. Turning the system to "off" will instantly turn all outputs off. The thermostat can be reset by pressing the system switch button and the service status button simultaneously.

Analog Output Not Working Properly

Check wiring. A separate transformer should be used for the SZ1017a, SZ1041, SZ1051, or SZ1053, and a separate transformer should be used for the motor(s). Check to make sure that the analog output is programmed correctly.

Check the Service Menu. The Mod Out Screen will tell you what the SZ1041 or SZ1051 is trying to put out. Compare this with the actual position on the heating or cooling device.

There are two conditions that must be met before the economizer analog output will modulate. First, there must be a call for cooling. Second, the outdoor air temperature must be less than the setting set in programming step #31b (for the SZ1041) or #30a (for the SZ1051).

Put the SZ1041 or SZ1051 into occupied mode. You should be able to adjust the output by going to programming step #35b (for the SZ1041) or #34a (for the SZ1051) and varying the minimum position setting. You need to exit programming before the change will take effect.

SERVICE SCREENS

Continually pressing the service status button allows more extensive monitoring. The screens are shown on the following page.

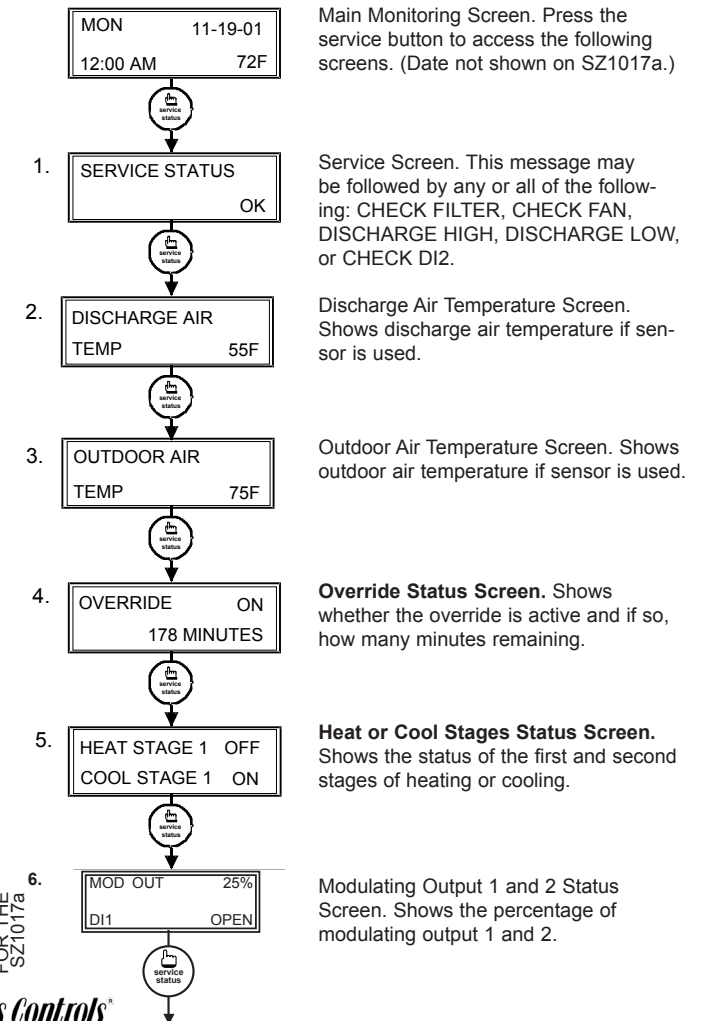

FOR THE SZ1051

FOR THE SZ1041

FOR THE SZ1053

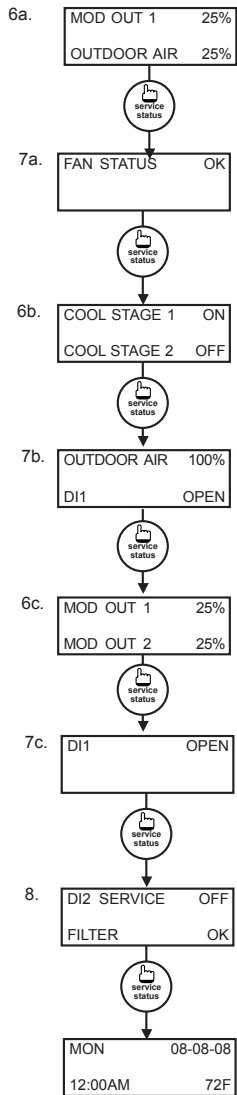

DI1 Status Screen. Shows the status of the fan interlock or DI1.

Cool Stages Status Screen. Shows the status of the first and second stages of cooling.

Damper Position and DI1 Status Screen. Shows the position of the damper output and the status of the fan interlock if DI1 is set for fan interlock.

Modulating Output 1 and 2 Status Screen. Shows the percentage of modulating output 1 and 2.

DI1 Status Screen. Shows the status of the fan interlock or DI1.

Mod Out and DI1 Status Screen. Shows the percentage of modulating output and the status of the fan interlock, or DI1.

DI2 and DI3 Status Screen. Shows DI2 status and filter status or DI3 status.

Main Monitoring Screen. (Date not shown on SZ1017a.)

SERVICE

This LED will be lit when the high or low discharge air limit has been reached, when the fan interlock has indicated failure, or when the filter service or service input are closed.

PROGRAM/DATA

This LED will be lit when the thermostat is within the programming or clock setup menus. It will blink when the unit is being accessed by a PC.

Additional monitoring is available by continually pressing the service key.

Limiting Occupant Access

SETPOINT ADJUSTMENT

The occupant may temporarily change the occupied heating and cooling setpoints +/- 5°F by factory default. This setpoint change will remain until the end of the current occupied period, at which time the program reverts to the setpoints defined in programming. To change the range of adjustment allowed, see programming step #14.

OVERRIDE

The occupant has the ability to put the unit into occupied mode by pressing the override button on the front. By factory default, the unit will remain in the occupied mode for 180 minutes. This value may be changed from 0 to 255 minutes in programming step #15.

FAN SWITCHING

The option to allow the occupant to change the occupied fan mode is allowed by factory default. To lock out access to fan switching, see programming step #7.

SYSTEM SWITCHING

The option to allow the occupant to change the system mode is allowed by factory default. To lock out access to system switching, see programming step #5.

SETTING CLOCK & SCHEDULE

The ability to set the clock and schedule is allowed by factory default. An access code may be required as set in programming step # 52, or access may be denied altogether using dialswitches described in the setup section.

PROGRAMMING

The ability to program control parameters is allowed by factory default. An access code may be required as set in programming step # 51, or access may be denied altogether using dialswitches described in the setup section.

LED Description

Six LEDs on the face allow the occupant to view the current operating status of the thermostat.

OCCUPIED

This LED will be lit whenever the unit is operating in the occupied mode.

HEATING

This LED will be lit when any heat output is operating.

COOLING

This LED will be lit when any cooling output is operating.

FAN

This LED will be lit when the fan output is closed.

- Occupied
- Heating
- Cooling
- Fan
- Service
- Program/Data

User's Guide

Inside the hinged door of the thermostat is the Superstat™ User's Guide. This guide is designed to assist the installer in explaining to the end user how to operate their new thermostat, as well as serve as a handy future reference for the end user.

We recommend that the installer fill out the appropriate pages and explain to the user how the thermostat operates, what settings may be changed, and how the time clock schedules are used.

